



Martin Pneumatic Ball and Roller Vibrators Series UCV / UCVR

- Rotary vibration
- Nominal frequency 6750 min⁻¹ to 19900 min⁻¹ (ball) - 9800 min⁻¹ to 12300 min⁻¹ (roller)
- Force output 110 N to 34345 N (ball) - 490 N to 14130 N (roller)
- Cast iron body
- Frequency and force adjustable by air pressure





Martin Pneumatic Ball and Roller Vibrators Series UCV / UCVR

model	frequency min ⁻¹			force output N			working moment	air consumption l / min		
	200	400	600	200	400	600		200	400	600
kPa >	200	400	600	200	400	600	mm.kg	200	400	600
UCV 6	19900	23500	25750	50	80	110	n/a	70	125	155
UCV 13	13150	19000	22400	165	345	490	0.09	85	225	310
UCV 19	12500	15750	17950	690	1130	1570	0.4	140	275	535
UCV25	8600	10800	12200	1080	1765	2260	1.2	210	325	465
UCV 32	5800	7350	8300	1100	1715	2355	2.8	225	430	680
UCV 38	4850	6100	6750	1375	2355	3435	5.5	280	520	805
UCVR 4-05	9800	13900	21100	490	785	3235	0.575	86	268	430
UCVR 6-5	6700	9700	10550	2415	6080	7065	5.76	325	580	820
UCVR 8-2	5000	6050	7600	6080	9025	13100	23	764	1273	1868
UCVR 8-08	9200	10400	12300	6870	10990	14130	9.2	863	1273	1556

Model	A mm	B mm	C mm	D mm	E mm	F mm	G mm	H bolt size	I mm	J bsp/npt
UCV 6	95	52	30	28	24	76	6	M6	16	1/8"
UCV 13	127	66	33	36	36	102	8	M10	19	1/8"
UCV 19	127	86	43	48	45	102	10	M10	24	1/4"
UCV 25	165	98	51	54	55	127	11	M12	32	1/4"
UCV 32	165	116	59	60	65	127	12	M12	40	3/8"
UCV 38	197	132	67	73	66	152	14	M12	48	3/8"
UCVR 4-05	127	86	39	48	45	101	10	M10	24	1/4"
UCVR 6-5	197	132	102	73	74	152	14	M16	48	3/8"
UCVR 8-2	254	175	101	95	103	203	20	M20	71	3/4"
UCVR 8-08	254	175	101	95	103	203	20	M20	71	3/4"

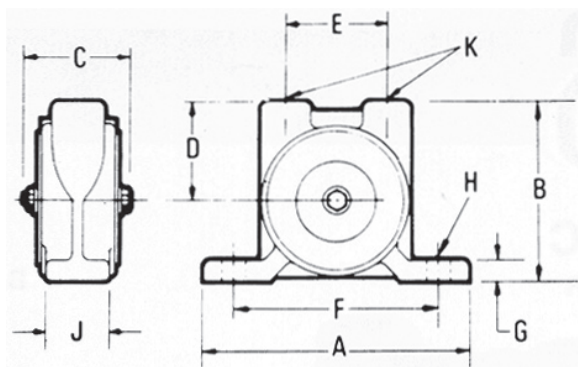

Applications

UCV / UCVR vibrators are used for moving material from hoppers. The rotary action is ideal for moving product down chutes. The cast iron body makes them suitable for underground use.

Design

Precision machined ball / roller is driven around a hardened race by air pressure. Adjusting the pressure changes the frequency and force output.

Operating Conditions

Drive medium:

Compressed air with filter and with lubrication

Operating pressure:

200 kPa to 600 kPa

Ambient Temperature;

-20 to 150° C

-20 to 180° C with air bleed

VSS offers the accessories required for the mounting, installation and control of vibrators and interval impactors.

VSS provides provides solutions. Consult our experienced application technicians.

Vibration Systems & Solutions (Australia)

Branches in all States

1800 300 877

sales@vibrationsystems.com.au

www.vibrationsystems.com.au

