



24

Netter Pneumatic Linear Vibrators Series NTK



- Linear vibration
- Nominal frequency from 420 min⁻¹ to 3,800 min⁻¹
- Centrifugal force from 14 N to 4,748 N
- Variable additional weights
- Frequency and amplitude are separately adjustable
- Stainless steel version available
- Ex II 2 GD 85°C (T6) available (ATEX)



NTK 8 AL



NTK 25



NTK 55 AL



Netter Pneumatic Linear Vibrators Series NTK

The table shows the most frequent ratings of piston vibrators series NTK.

1 "Piston" means, that the piston vibrates, the housing is bolted to the mass to be operated.

2 The additional weights SM increase the mass of the piston and in consequence the amplitude.

3 "Housing" in the table means that the vibrator is fixed to the piston and allows additional

combinations.

4 Some vibrators may be fitted with additional weights SM at the housing.

Methods of attachment

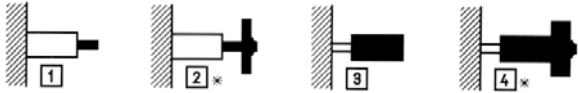

*in case of horizontal mounting with weights, please pay particular attention to the operating manual!

Type	Oscillating part		Working moment [mmkg]			Nominal frequency [min ⁻¹]			Centrifugal force [N]			Air consumption [l/min]***	Noise level [dB(A)]
	Assembly	Mass [kg]**	200 kPa	400 kPa	600 kPa	200 kPa	400 kPa	600 kPa	200 kPa	400 kPa	600 kPa	200 kPa – 600 kPa	200 kPa – 600 kPa
NTK 8 AL*	Piston	0.030	0.05	0.06	0.06	2,440	3,120	3,657	15	32	44	7 – 32	61 – 75
	Piston + SM 8-1	0.046	0.08	0.10	0.10	1,858	2,412	3,000	16	32	48	6 – 31	
	Piston + 2 x SM 8-1	0.058	0.09	0.14	0.15	1,680	2,100	2,571	14	33	54	6 – 29	
	Piston + SM 8-2	0.088	0.15	0.37	0.21	1,380	1,333	2,080	15	36	50	6 – 25	
NTK 15 x*	Piston	0.135	0.29	0.33	0.29	1,745	2,182	2,544	49	85	104	17 – 72	53 – 64
	Piston + SM 16-1	0.455	0.81	1.17	1.27	1,029	1,137	1,343	47	83	126	16 – 57	
	Piston + SM 16-2	0.675	1.69	3.06	1.69	758	720	1,152	53	87	123	14 – 54	
NTK 16	Piston	0.150	0.27	0.37	0.34	1,680	1,920	2,400	42	75	106	14 – 58	54 – 67
	Piston + SM 16-1	0.470	1.14	1.48	1.48	908	1,309	1,527	52	139	189	11 – 44	
	Piston+SM16-1+SM 16-2	0.990	2.96	3.02	2.96	686	914	1,085	76	139	191	8 – 41	
	Housing	1.330	4.90	4.60	4.50	600	778	923	96	153	210	8 – 39	
NTK 18 AL*	Piston	0.210	0.29	0.33	0.36	1,600	1,980	2,350	41	70	109	19 – 68	55 – 68
	Piston + SM 16-1	0.530	1.18	1.47	1.41	972	1,321	1,572	61	141	191	13 – 58	
	Piston + SM 16-2	0.750	1.96	2.29	2.16	878	1,168	1,371	83	171	223	11 – 56	
	Piston + SM 16-1+SM 16-2	1.050	3.27	3.27	3.21	738	965	1,174	98	167	242	10 – 50	
NTK 25 AL*	Piston	0.420	1.18	1.38	1.24	1,289	1,821	1,986	107	250	269	34 – 149	56 – 73
	Piston + SM 25-1	0.775	2.59	2.95	2.88	988	1,371	1,622	139	304	415	26 – 138	
	Piston + SM 25-2	0.970	3.54	3.86	3.67	894	1,237	1,477	155	324	439	24 – 127	
	Piston + SM 25-3	1.655	6.88	6.94	6.55	686	898	1,080	177	307	419	22 – 115	
	Piston + 2 x SM 25-3	2.840	11.79	11.46	11.13	540	823	943	188	425	543	21 – 104	
NTK 25	Piston	0.470	1.12	1.36	1.32	1,440	1,946	2,270	127	282	374	38 – 156	57 – 73
	Piston + SM 25-2	1.020	3.07	3.62	3.76	993	1,320	1,655	166	346	565	28 – 115	
	Piston + SM 25-3	1.705	5.58	6.41	6.34	800	988	1,292	196	343	581	25 – 105	
	Housing	2.600	9.10	9.95	9.82	690	911	1,067	237	452	612	24 – 102	
	Housing + SM 25-2	3.150	9.82	11.62	11.29	649	847	973	226	457	586	23 – 100	
	Housing + SM 25-3	3.835	11.45	14.07	13.74	609	780	933	233	469	656	23 – 100	
NTK 40 AL*	Piston	1.240	2.88	2.64	2.16	1,231	1,620	2,094	239	380	519	54 – 220	58 – 70
	Piston + SM 25-3	2.475	6.72	8.40	7.44	900	1,168	1,389	298	628	787	36 – 210	
	Piston + 2 x SM 25-3	3.660	13.08	13.20	12.96	710	923	1,169	361	617	971	34 – 173	
	Piston + SM 25-4	4.910	24.24	20.64	18.72	565	780	985	424	689	995	33 – 152	
	Piston	1.270	3.57	3.57	2.46	1,200	1,629	1,930	282	520	503	49 – 228	
NTK 40	Piston + SM 25-3	2.505	7.39	8.62	8.50	889	1,175	1,433	320	653	957	38 – 188	58 – 70
	Piston + 2 x SM 25-3	3.690	12.07	14.17	13.80	673	933	1,206	300	677	1,100	35 – 165	
	Housing	4.200	19.48	17.08	16.36	600	840	1,108	385	661	1,100	34 – 161	
	Piston + SM 25-4	4.940	27.10	22.67	19.71	554	778	980	456	753	1,037	32 – 152	
	Housing + SM 25-3	5.435	33.44	26.34	21.65	519	738	933	494	788	1,034	29 – 145	
NTK 55 AL*	Piston	2.100	3.62	3.50	2.66	1,500	1,920	2,400	447	708	839	98 – 398	62 – 71
	Piston + SM 85-1	3.430	7.25	7.25	6.28	1,113	1,440	1,768	492	824	1,077	83 – 384	
	Piston + 2 x SM 85-1	4.610	11.11	10.87	9.90	985	1,292	1,500	591	995	1,222	81 – 371	
	Piston + SM 85-2	5.870	14.49	14.49	13.28	884	1,175	1,371	621	1,097	1,370	79 – 366	
	Piston + 2 x SM 85-1+SM 85-2	8.285	22.94	22.22	20.29	758	1,011	1,200	723	1,244	1,602	73 – 355	
NTK 55 HF	Piston	2.100	2.49	2.74	2.49	1,760	2,352	2,836	423	831	1,099	65 – 295	64 – 74
	Piston + SM 85-2	3.430	4.98	6.35	6.11	1,380	1,705	2,050	520	1,013	1,407	53 – 291	

Type	Oscillating part		Working moment [mmkg]			Nominal frequency [min ⁻¹]			Centrifugal force [N]			Air consumption [l/min]**	Noise level [dB(A)]
	Assembly	Mass [kg]**	200 kPa	400 kPa	600 kPa	200 kPa	400 kPa	600 kPa	200 kPa	400 kPa	600 kPa	200 kPa - 600 kPa	200 kPa - 600 kPa
NTK 55 NF	Piston	2.100	4.08	3.60	2.88	1,405	1,879	2,351	441	696	872	101 - 408	62 - 71
	Piston + 2 x SM 85-1	4.610	11.03	11.75	10.55	973	1,358	1,611	573	1,189	1,501	69 - 345	
	Housing	5.900	14.40	15.09	13.47	884	1,206	1,467	617	1,204	1,588	64 - 330	
	Piston + SM 85-1 + SM 85-2	7.050	18.94	19.66	18.22	853	1,140	1,380	755	1,401	1,903	63 - 321	
	Piston + SM 85-3	14.630	41.37	41.97	41.97	677	862	1,015	1,039	1,708	2,371	62 - 317	
	Housing + SM 85-3	18.430	46.44	52.25	49.92	649	823	960	1,071	1,940	2,523	61 - 286	
NTK 85 HF	Piston	5.200	3.01	3.76	3.88	2,520	3,120	3,800	1,047	2,006	3,075	118 - 431	64 - 79
	Piston + 2 x SM 85-1	7.710	5.01	6.39	6.27	2,031	2,466	2,954	1,133	2,130	2,997	120 - 446	
NTK 85 NF	Piston	5.200	3.91	4.67	5.04	1,892	2,400	2,830	767	1,474	2,215	166 - 545	61 - 76
	Piston + SM 85-1	6.530	6.31	6.56	6.56	1,622	2,108	2,514	910	1,597	2,273	167 - 544	
	Piston + SM 85-2	8.970	9.58	10.09	10.09	1,345	1,714	2,067	950	1,626	2,364	159 - 536	
	Housing	12.100	13.59	14.07	13.11	1,200	1,543	1,838	1,073	1,836	2,428	148 - 532	
	Piston SM 85-3	17.500	25.47	26.48	24.21	894	1,166	1,407	1,116	1,975	2,627	128 - 513	
	Piston + SM 85-2 + SM 85-3	21.000	32.16	32.79	30.89	821	1,060	1,297	1,187	2,021	2,851	120 - 505	
	Piston + SM 85-4	28.900	45.40	51.70	45.40	707	879	1,076	1,244	2,191	2,880	111 - 494	
Piston + SM 85-5	40.750	69.36	75.66	73.14	592	784	914	1,333	2,548	3,352	103 - 452		
NTK 110	Piston	8.000	6.03	7.87	7.87	2,133	2,571	3,040	1,505	2,852	3,986	210 - 652	62 - 78
	Piston + SM 85-2	11.770	9.18	11.27	11.80	1,760	2,160	2,538	1,559	2,884	4,169	209 - 650	
	Housing	16.600	13.48	15.68	15.93	1,447	1,846	2,133	1,548	2,930	3,974	207 - 634	
	Piston + SM 85-3	20.530	17.04	19.93	20.98	1,324	1,655	1,964	1,638	2,993	4,435	206 - 631	
	Piston + SM 85-2 + SM 85-3	24.090	21.24	23.60	24.65	1,200	1,527	1,821	1,677	3,018	4,480	203 - 628	
	Piston + SM 85-4	31.990	29.89	32.78	32.51	1,046	1,292	1,632	1,794	3,001	4,748	191 - 614	
	Piston + SM 85-5	44.455	38.67	44.57	41.95	900	1,143	1,371	1,718	3,192	4,326	180 - 606	

* For lubrication free operation contact our application technicians.

Subject to technical modifications.

** All weights inclusive fixing bolt. ***Normal litre = uncompressed air. NTK 16, 25, 40, 55, 85 and 110 operation is possible up to 16 bar. Technical data may vary depending on application. Please request comparative values.

NTK weights

Piston, housing, total weight

Vibrator	Piston [kg]	Housing [kg]	Total weight [kg]	Possible combinations	Additional weights	Dimensions [Ømm x mm]	Bore [Ømm]	Weight [kg]
NTK 8 AL	0.03	0.06	0.09	The combination of vibrators and weights in the same group is possible.	SM 8-1	17 x 8	5.0	0.012
NTK 15 x	0.13	0.32	0.45		SM 8-2	30 x 10	5.0	0.053
NTK 16	0.15	1.34	1.49		SM 16-1	50 x 20	10.5	0.29
NTK 18 AL	0.21	0.53	0.74	See table page 2 and page 3.	SM 16-2	65 x 20	10.5	0.51
NTK 25 AL	0.43	0.50	0.92		SM 25-1	50 x 20	16.5	0.27
NTK 25	0.47	2.63	3.10		SM 25-2	65 x 20	16.5	0.47
NTK 40 AL	1.28	1.01	2.29		SM 25-3	100 x 20	16.5	1.18
NTK 40	1.29	4.0	5.49		SM 25-4	100 x 60	16.5	3.60
NTK 55 AL	2.10	1.75	3.85		SM 85-1	100 x 20	20.5	1.16
NTK 55 HF	2.10	5.60	7.70		SM 85-2	100 x 60	20.5	3.50
NTK 55 NF	2.10	5.90	8.00		SM 85-3	200 x 50	20.5	12.30
NTK 85 HF	5.20	11.30	16.50		SM 85-4	200 x 100	20.5	23.70
NTK 85 NF	5.20	12.10	17.30		SM 85-5	200 x 150	20.5	35.55
NTK 110	8.00	16.60	24.60					

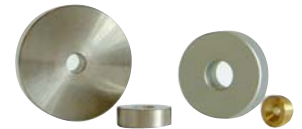

Applications

Additional weights SM are used to increase the working moment. While fixing additional weights on the moving part of the vibrator, the working moment and also the amplitude are individually adjustable.

The additional weights are available in different sizes. All weights are made of nickel-plated steel, except SM 8-1 which is made of brass.

Netter Bellows

Series NFB

Bellow	Vibrator	Inside diameter [mm]	Outside diameter [mm]
NFB 20	NTK 15 x, 16, 18 AL	20	50
NFB 25	NTK 25 AL	30	65
NFB 30	NTK 25	30	65
NFB 45	NTK 40	45	85
NFB 60	NTK 55	60	110
NFB 90	NTK 85	90	140
NFB 115	NTK 110	115	165

Applications

The bellows series NFB for linear vibrators series NTK are designed for the protection of the piston against outside influences such as dirt and dust. NFB bellows are available for all types from NTK 15x up to NTK 110. They are easily removable by velcros and make the flats of the piston accessible.





Netter Pneumatic Linear Vibrators Series NTK

Type	ØA [mm]	ØB [mm]	C [mm]	E [mm]	F [mm]	G* [mm]	H	ØJ [mm]	ØK [mm]	L	M	ØQ** [mm]	R [mm]	S [mm]	T [mm]	U [mm]	SW [mm]
NTK 15 x	15	50	114	9	38	23.5	M10	-	-	G 1/8	G 1/8	-	20	10	55	99	13
NTK 16	16	49	111	5	38	21.5	M10	-	-	G 1/8	G 1/8	-	21	10	57	96	14
NTK 18 AL	18	49	116	8	42	25.0	M10	-	-	G 1/8	G 1/8	-	21	10	62	101	16
NTK 25	25	64	138	9	52	30.5	M16	-	-	G 1/4	G 1/4	-	25	10	73	125	22
NTK 40	40	84	140	12	54	33.0	M16	-	-	G 3/8	G 1/4	-	40	15	73	123	32
NTK 55 NF	55	110	125	19	55	38.0	M20	96	-	G 3/8	G 3/8	4 x 8,5	40	30	60	108	46
NTK 55 HF	55	110	115	29	65	47.0	M20	96	-	G 3/8	G 3/8	4 x 8,5	40	30	50	98	46
NTK 85 NF	85	160	122	20	45	32.5	M20	143	12,8	2 x G 3/8	G 3/8	6 x 10,5	40	20	57	105	-
NTK 85 HF	85	160	112	30	55	42.5	M20	143	12,8	2 x G 3/8	G 3/8	6 x 10,5	40	20	47	95	-
NTK 110HF	110	200	122	22	55	38.5	M20	182	12,8	2 x G 1/2	2 x G 3/8***	8 x 12,5	40	25	57	105	-

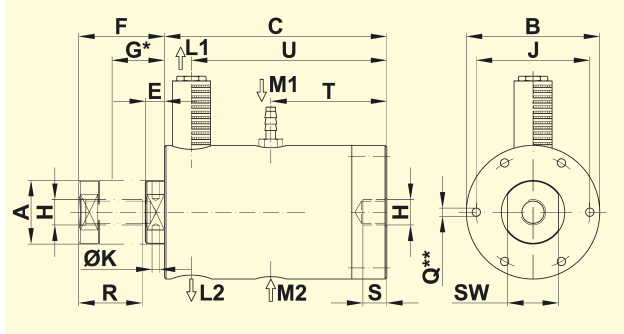

* centre of vibration
** additional forms of attachment from NTK 55 upwards
*** optional M₁ or M₂

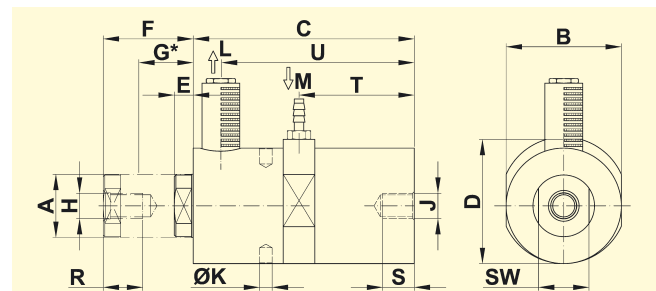

Type	ØA [mm]	B [mm]	C [mm]	D [mm]	E [mm]	F [mm]	G* [mm]	H	J	ØK [mm]	L	M	R [mm]	S [mm]	T [mm]	U [mm]	SW [mm]
NTK 8 AL	8	22	91	22	5	32	18.5	M 5	M 6	-	M 5	M 5	15	7	47	76.5	7
NTK 25 AL	25	50	138	54	7	52	29.5	M 16	M 16	-	G 1/4	G 1/4	25	18	72	120.5	22
NTK 40 AL	40	73	140	79	12	57	34.5	M 16	M 16	8	G 3/8	G 1/4	25	20	73	122.5	32
NTK 55 AL	55	98	133	109	20	58	38.5	M 20	M 20	10	G 3/8	G 3/8	40	35	66	115.0	46

* centre of vibration

Applications

The pneumatic linear vibrators series NTK are especially suitable for conveying, compacting and loosening bulk material, due to the completely linear vibration. They may also serve to stimulate and influence production processes.

A special feature of the NTK vibrators is the variety of mounting options. It is possible to attach the housing or the piston to a vibrating mass. Additional weights SM allow to adjust the frequency and the amplitude in many different ways.

Design and functioning principle

The vibration (linear) is produced by a freely oscillating, self reversing piston. NTK linear vibrators start and stop instantly in any installed position. The noise level is lower than 80 dB(A). The frequency can be adjusted continuously by regulating the air supply. The amplitude can be adjusted by throttling the exhaust air.

Vibrators with aluminium housing series NTK AL as well as type NTK 15x may be operated

lubrication-free in compliance with instructions of **NetterVibration**. NTK vibrators with steel housing require lubricated air. For operation a control valve is required (not included in scope of delivery). ATEX compliant linear vibrators of the NTK series and units with stainless steel housing are available.

Permissible operating conditions

Drive medium:

Compressed air or nitrogen (Filter ≤ 5 µm), preferably with oil mist

Operating pressure:

200 kPa to 600 kPa

Ambient temperature:

NTK AL 5°C to 60°C

NTK 15 x 5°C to 100°C

NTK with steel housing -10°C to 150°C

HT version up to 200°C

VSS offers the accessories required for mounting, installation and control of vibrators and interval impactors.

VSS provides solutions.

Consult our experienced application technicians.

Vibration Systems & Solutions (Australia)

Branches in all States

1800 300 877

sales@vibrationsystems.com.au

www.vibrationsystems.com.au



NetterVibration

